

The switching relay is set up so it switches power to either the 'run' or the 'start' contactor coil. The contactors are from left to right, start, run and power. I am using 200uf start, 34 uf C1-C2 and 57 uf C3-C2, thats with a 7.5 HP idler motor. The start and run contactors can use 440Vac coils, the power contactor can as well but it the coil will stay energised while the field in the motor collapses. a 440Vac coil seems to switch OK with rectified 240Vac. I decided on 9k and 33uf but in fact am using 66uf and 18k I think. it's a case of tuning it. if the motor grumbles your switching the run caps out to late. when you turn it on it should spin up pretty quickly and you wouldn't know anything has switched. If you series any caps put a bleed resistor across them so they don't retain voltage. I went for something like 1K resistors.

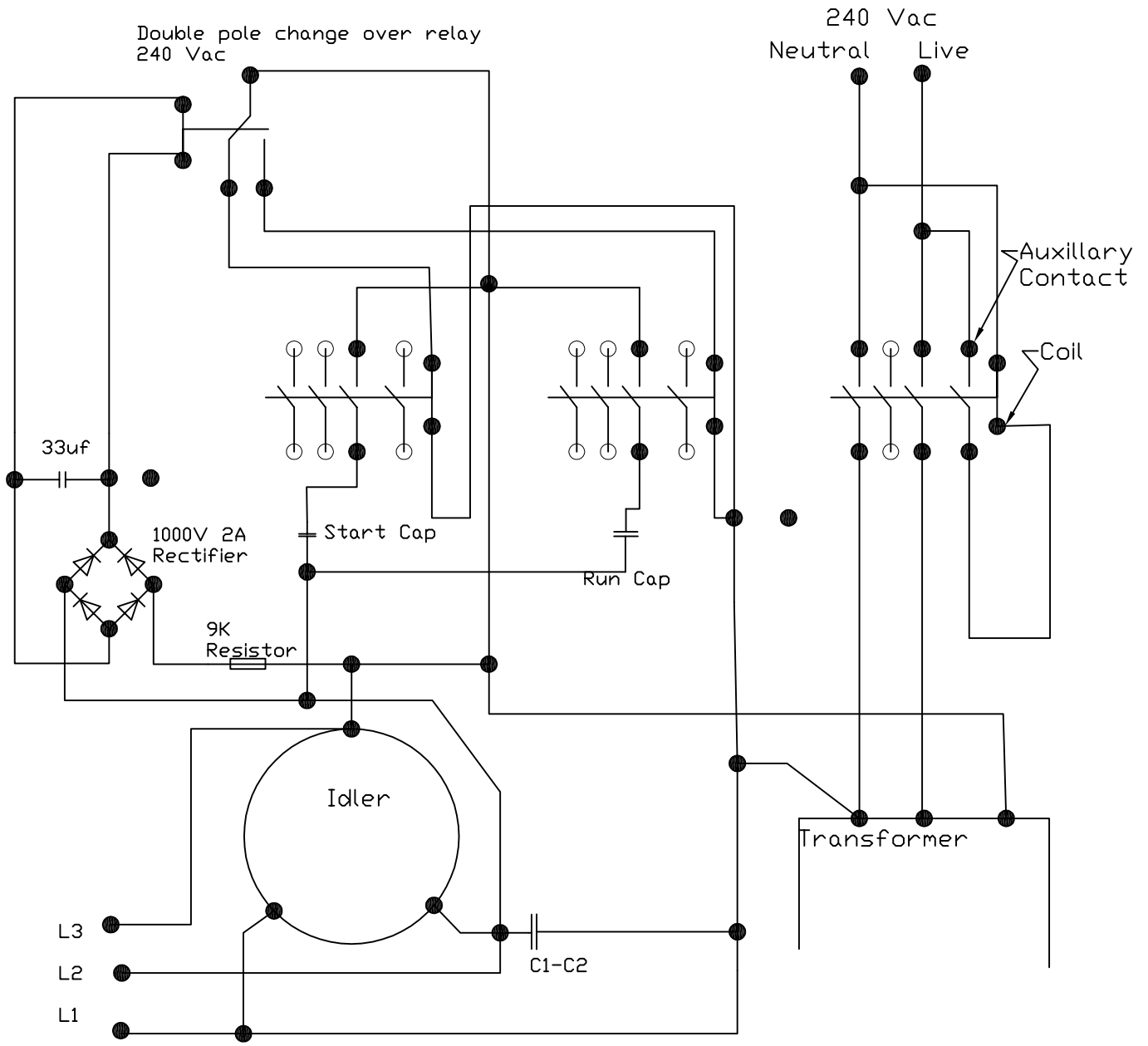

| | | | | | | | | |
|----------------------|----------|-------|-------------|----------|-------------|---|---------------|-----------|
| (Verwendungsbereich) | | | (Zul. Abw.) | | (Oberfl.) | Maßstab 1:1 | | (Gewicht) |
| | | | | | | (Werkstoff, Halbzeug) (Rohteil-Nr) (Modell- oder Gesenk-Nr) | | |
| | | | | Datum | Name | IntegerSpin | | |
| | | | Bearb. | 00.00.00 | XXX | | | |
| | | | Gepr. | 00.00.00 | XXX | | | |
| | | | Norm | | | | | |
| | | | | | | Rotary Converter Switching Wiring | | Blatt |
| | | | | | | | | Blätter |
| Zust | Änderung | Datum | Name | Ursprung | Ersatz für: | | Ersatz durch: | |